

MAC100B

Single Flavor Acai Berry Serve Machine
Soft Serve Freezer

Features:

- With a complete stainless-steel body this machine guarantees quality, durability all while facilitating the cleaning process of the equipment.
- Produces up to 32 quarts (8 gallons) per hour
- With a production capacity of 100x 10oz bowls per hour. Produce nearly 2 bowls of Acai per minute.
- Freezing Cylinder: Two, 1.9-quart cylinders (3.6 liters)
- Mix Hopper: One, 9.5 quart (9 liters)
- All washable parts are injection molded, highly durable plastic.
- Height-adjustable feet to maintain leveled machine
- Air Cooled Machine
- 2 HP Beater Motor
- 1.5 HP Compressor
- Digital Control Panel
- Operational Modes: Serve, Conservation, Cleaning/Defrost
- Texture Control
- Low Mix Indicator Lights alerts operator to add mix.
- Refrigerated Hoppers that maintain mix below 41°F (5°C) during Serve and Conservation modes.
- During long no-use periods, the conservation feature maintains safe product temperatures in the mix hopper and freezing cylinder.
- Hopper temperature is displayed to assure safe product temperatures.



Left Side

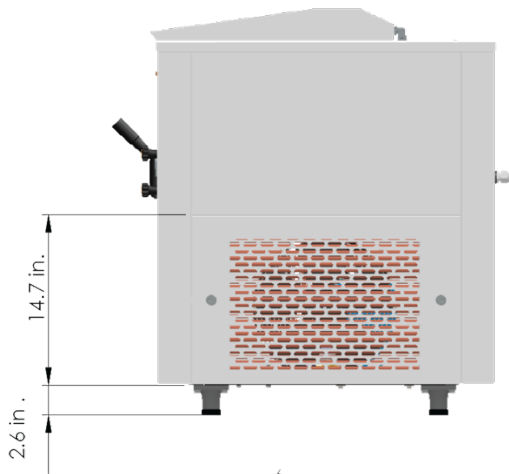

Front

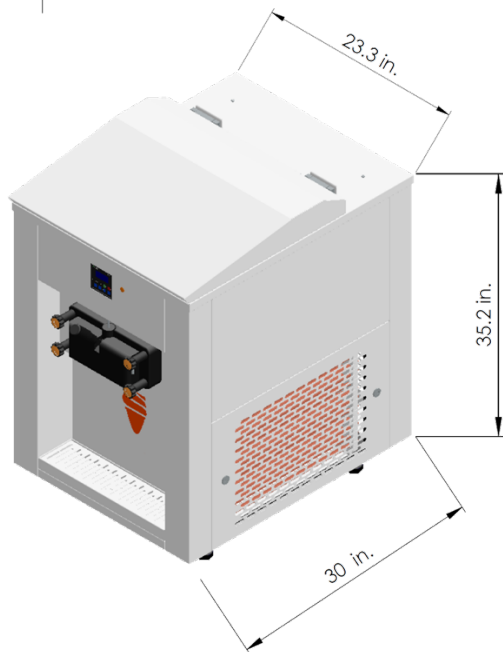
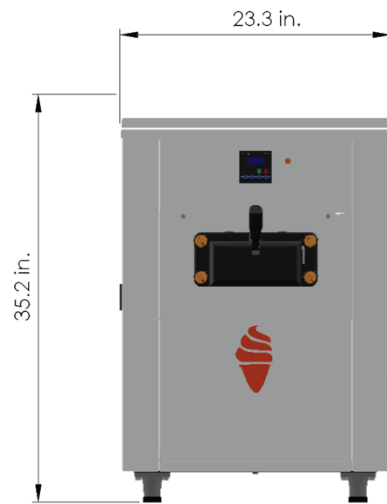

3D View

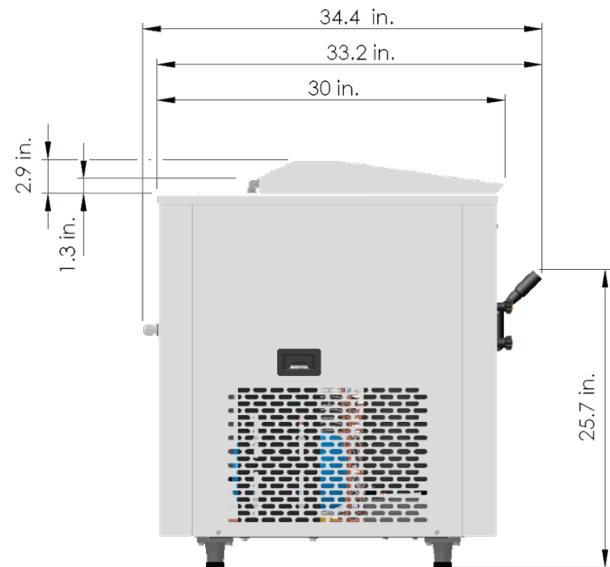

Right Side

INSTALLATION REQUIREMENTS

- Machine must be installed on level surface

CLEARANCE REQUIREMENTS

LEFT: 6" (150MM)	RIGHT: 6" (150MM)
TOP: 24" (610MM) FOR LID OPENING	
BACK: 0" (0MM)	BOTTOM: 2.5" (64MM)

IMPORTANT: Do not cover side vents of machine. Machine requires adequate spacing for proper ventilation. Lack of ventilation can damage the condenser, compressor and other components and doing so could lead to warranty being voided.

ELECTRICAL (CORD INCLUDED, NO PLUG, DEDICATED CIRCUIT REQUIRED)

VOLTAGE: 220v	PHASE: Single
HERTZ: 60	AMPS: 24A
WATTS: 5,280	AWG: 10
ENERGY CONSUMPTION: 5.3 kW/hr	

DIMENSIONS: L x D x H

EXTERIOR: 23.3" x 30" x 35.2" (593mm x 762mm x 894mm)
WEIGHT: 352 lbs. (160kg)

SHIPPING

DIMENSIONS: 28" x 43.3" x 39.4" (710mm x 1100mm x 1000mm)
WEIGHT: 405 lbs. (185kg)
CLASS: 100

WARNING: This product can expose you to chemicals including arsenic, which is known to the State of California to cause cancer. For more information, go to www.P65Warnings.ca.gov